

DESCRIPTION

TL Pressure Reducing Valve is designed for automatically reduce the pressure to a lower "preset pressure" and constant flow regardless of fluctuations of inlet pressure as long as the supply pressure does not drop below the preset pressure.

We recommend to install a self cleaning filter or Y-Strainer upstream before the pressure reducing valve in case of dirty fluids. It can be installed in horizontal or vertical

#TL-15/SS - CAST IRON/CF8



SPECIFICATION

- Direct acting pressure reducing valve
- Max. inlet pressure 10bar
- Adjustable outlet pressure 1 to 4 bar
- Preset pressure at 3 bar
- Threaded end BSPT

APPLICATIONS

- Suitable for water steam and fluid compactible to the "Material of construction"
- Max. temperature 200°C

MATERIAL of construction

PART NAME	TL-15	TL-15SS
1. Body	Cast Iron	CF8
2. Gasket	Asbestos	Asbestos
3. Plug	Cast Iron	CF8
4. Spring	SUP-6	SUP-6
5. Knob	PTFE	PTFE
6. Stem	CF8	CF8
7. Guide	CF8	CF8
8. Gasket	Asbestos	Asbestos
9. Bolt	SS41	CF8
10. Knob	SS41	SS41
11. Spring	SUP-6	SUP-6
12. Holder	SS41	SS41
13. Cover	Cast Iron	CF8
14. Nut	SS41	CF8
15. Screw	SS41	CF8
16. Cap	Cast Iron	CF8
17. Diaphragm	AIS-301	AIS-301

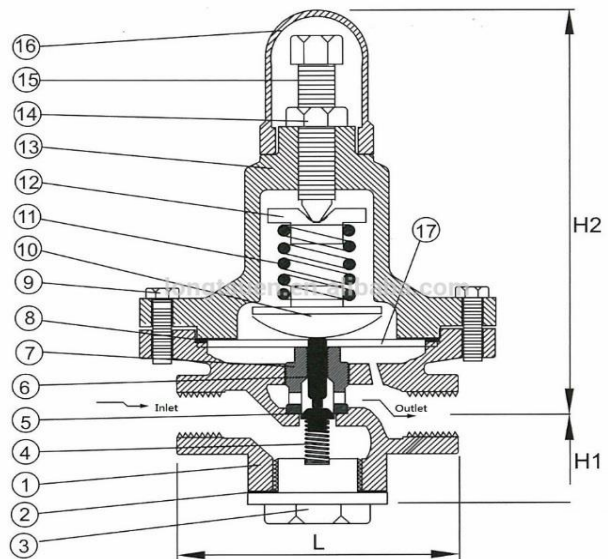

DIMENSIONS (mm)

Size (inch)	1/2	3/4	1	1-1/4	1-1/2	2
DN	15	20	25	32	40	50
L	95	95	59	130	130	168
H1	55	55	55	72	72	90
H2	185	185	185	205	205	260
Weight (kg)	4	4.2	4.4	6.5	7	13

The specification and dimensions are subject to change without prior notice!